

10023

Reg. No.: \_\_\_\_\_

Name: \_\_\_\_\_

**APJ ABDUL KALAM TECHNOLOGICAL UNIVERSITY**  
**FIRST/SECOND SEMESTER B.TECH DEGREE SPECIAL EXAMINATION, SEPT 2016**  
**EE100 BASICS OF ELECTRICAL ENGINEERING**

Max. Marks: 100

Duration: 3 Hours

**PART A**

*Answer all questions, each question carries 4 marks*

1. State and explain Kirchhoff's law.
2. Three resistors  $R_1=20 \Omega$ ,  $R_2=90\Omega$  and  $R_3=10 \Omega$  are connected in star. Obtain the equivalent delta circuit.
3. Define coefficient of coupling in a magnetic circuit.
4. A  $10\Omega$  resistor &  $400\mu\text{F}$  capacitor are connected in series to a  $240\text{V}$  sinusoidal ac supply. The circuit current is  $5\text{A}$ . Calculate the supply frequency & phase angle between current & voltage.
5. Explain the advantage of three phase system compared to single phase system.
6. Draw the single line diagram of a typical power transmission scheme.
7. Derive E.M.F. equation of a Transformer.
8. Explain the principle of operation of Universal motor.
9. Draw the schematic diagram of LT switch board.
10. Explain the working of MCB and ELCB

**PART B**

**MODULE (1-4)**

*Answer any four questions, each question carries 10 marks*

11. Calculate the current in each branch of the circuit shown using mesh analysis (10)

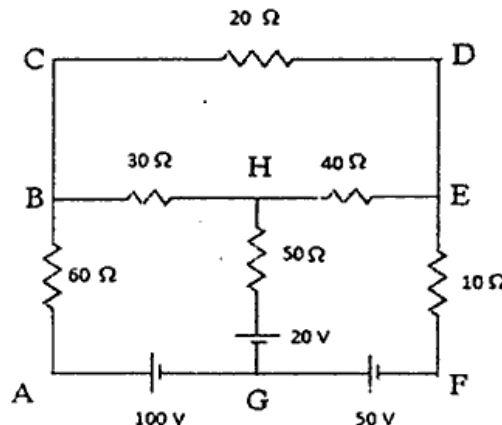

12. a) An iron ring of mean length 50cm has an air gap of 1mm and a winding of 200 turns. If the relative permeability of iron is 300 when a current of 1A flows through the coil, find flux density. Take permeability of air as  $4\pi \times 10^{-7}$  H/m. (5)  
b) Compare magnetic circuit and electric circuit. (5)
13. a) Determine average value & rms value of symmetrical square wave also find the form factor (6)

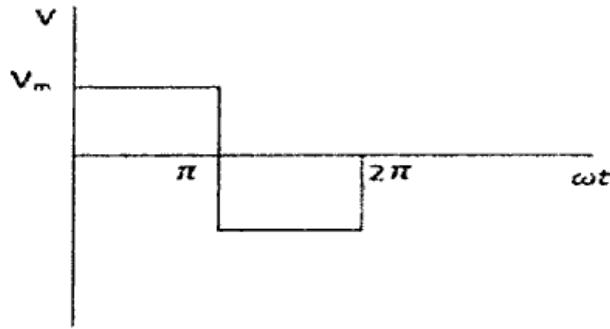

- b) Distinguish between self inductance and mutual inductance (4)
14. Three identical resistors of  $20\Omega$  each are connected in star to 415V, 50Hz three phase supply. Calculate (i) the total power consumed, (ii) total power consumed if they are connected in delta (iii) total power consumed, if one of the resistors is opened in both star connection and delta connections. (10)
15. With a neat schematic diagram explain Thermal power plant. (10)
16. Explain in detail the different equipment used in a substation. (10)

**MODULE 5**

*Answer any one full question*

17. The iron loss of 230/115V, 5KVA transformer is 200W. The copper loss at full load is 250W. Find efficiency of the transformer when delivering  
(i) full load power at unity power factor. (5)  
(ii) half full load power at 0.8 pf lagging. (5)

OR

18. Explain with neat diagram the construction and working principle of three phase induction motor. (10)

**MODULE 6**

*Answer any one full question*

19. a). Explain the necessity of earthing in electrical installation (4)  
b) With a neat sketch, explain the method of Plate Earthing (6)

OR

20. With the help of a diagram explain the principle of operation of compact fluorescent lamp and sodium vapour lamp. (10)

<http://www.ktuonline.com>

Whatsapp @ 9300930012

Your old paper & get 10/-

पुराने पेपर्स भेजे और 10 रुपये पायें,

Paytm or Google Pay से