

Reg. No _____

Name: _____

APJ ABDUL KALAM TECHNOLOGICAL UNIVERSITY
FIRST SEMESTER B.TECH DEGREE EXAMINATION, JANUARY 2017

EE100: BASICS OF ELECTRICAL ENGINEERING

Max. Marks: 100

Duration: 3 Hours

PART A

Answer all questions, each question carries 4 marks

1. State and explain Kirchhoff's laws.
2. Three resistors $R_1 = 30 \Omega$, $R_2 = 60 \Omega$, and $R_3 = 10 \Omega$ are connected in star. Obtain the equivalent delta circuit.
3. Explain Faraday's laws of electromagnetic induction and Lenz's laws.
4. A 10Ω resistor and 300 mH inductor are connected in series to a 230V sinusoidal supply. The circuit current is 4A. Calculate the supply frequency and phase angle between current and voltage.
5. Deduce the relationship between line and phase voltage in a star connected system.
6. Draw and explain a typical electrical power transmission scheme.
7. Explain the working principle of a DC motor.
8. What are the losses occurring in a transformer. Explain
9. Explain the working principle of a 3 phase induction motor.
10. Why a single phase induction motor is not self-starting. Explain.

PART B

MODULE (1-4)

Answer any four questions, each question carries 10 marks

11. Calculate the current in each branch of the following circuit using mesh analysis. (10)

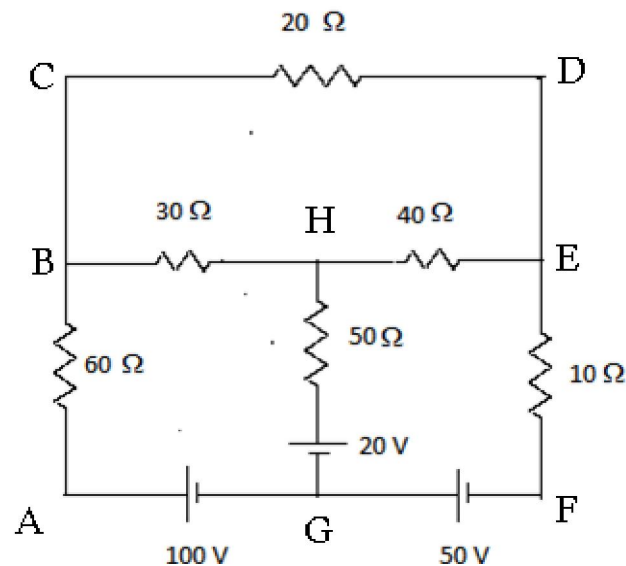

12. A steel ring of circular cross section of 1 cm in radius and having a mean circumference of 94.3 cm has an airgap of 1 mm long. It is uniformly wound with an exciting coil consisting of 600 turns and excited with a current of 2.5 A. Neglecting magnetic leakage calculate (i) m.m.f. (ii) Reluctance (iii) Magnetic flux (iv) Flux density (v) Relative permeability of steel. Assume that steel part takes about 40% of total ATs. (10)
13. a) Define peak factor and form factor of an alternating quantity. (4)
b) Derive the rms and average value of a sinusoidal waveform. (6)
14. Three inductive coils, each with a resistance of 22Ω and an inductance of .05 H are connected in (i) in star and (ii) in delta, to a three phase 415 V, 50 Hz supply. Calculate for each of the above case (i) phase current and line current and (ii) total power absorbed. (10)
15. With a neat schematic diagram, explain the working of a nuclear power plant. List any three advantages and any three disadvantages of a nuclear power plant. (10)
16. Explain about any two types of non - conventional energy sources available. (10)

MODULE 5

Answer any one full question

17. a) Derive an expression for back emf of a d.c. motor. (6)
b) A single phase transformer is to have a voltage rating of 3300/240V. Find the number of turns in the primary and the secondary if the frequency of operation is 50Hz. The maximum flux in the core may be taken as 0.04 Wb. (4)

OR

18. a) Explain different types of dc motors with respect to excitation and winding connection. (6)
b) A 220V dc series motor draws a current of 20A. The armature resistance is 0.1Ω and series winding resistance is 1.2Ω . Find the back emf. (4)

MODULE 6

Answer any one full question

19. a) Compare squirrel cage induction motor with slip ring induction motor. (4)
b) Explain any two starting methods used to start a single phase induction motor. (6)

OR

20. a) A four pole, three phase induction motor runs at 1440 rpm at rated load. Calculate the percentage slip. Supply frequency is 50 Hz. (4)
b) Explain the constructional details and working principle of a single phase induction motor. (6)
