

Reg No.: _____

Name: _____

APJ ABDUL KALAM TECHNOLOGICAL UNIVERSITY
FIRST SEMESTER B.TECH DEGREE EXAMINATION, DECEMBER 2017

Course Code: EE100

Course Name: BASICS OF ELECTRICAL ENGINEERING

Max. Marks: 100

Duration: 3 Hours

PART A

Answer all questions, each carries 4 marks

- | | | Marks |
|----|---|-------|
| 1 | Differentiate between Constant voltage and constant current sources. | (4) |
| 2 | Compare electric and magnetic circuits. | (4) |
| 3 | Derive the expression for RMS value of a sinusoidal waveform. | (4) |
| 4 | Write the expression for three phase power in a delta connected system. | (4) |
| 5 | What are the advantages of a hydroelectric power plant? | (4) |
| 6 | Explain the working principle of a photovoltaic cell. | (4) |
| 7 | Explain the working principle of a DC motor. | (4) |
| 8 | Derive the emf equation of a transformer. | (4) |
| 9 | Define and write the expression for slip of a 3 phase induction motor. | (4) |
| 10 | Explain the working of a capacitor start single phase induction motor. | (4) |

PART B

MODULE (1-4)

Answer any four questions, each carries 10 marks

- 11 a) Solve the following circuit using mesh analysis and find i_x (5)

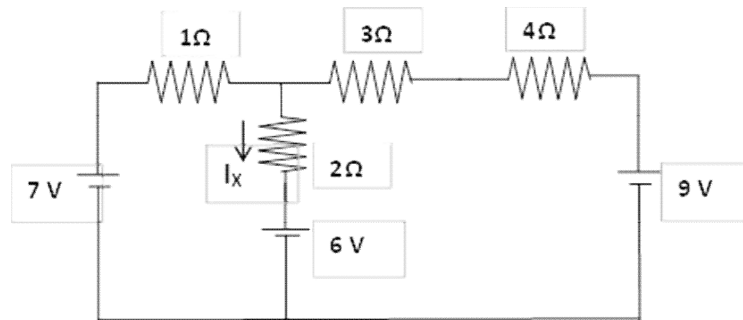

- b) With a sample circuit, explain the step by step procedure of nodal analysis. (5)
- 12 a) State and explain Faraday's laws of electromagnetic induction. (5)
- b) With suitable example, explain statically and dynamically induced emf. (5)
- 13 a) Define and obtain the expression for power factor, active power, reactive power and apparent power of a series RLC circuit. (5)
- b) A 50Ω resistor in series with $120\mu\text{F}$ capacitor is connected to 230V 50Hz supply. Find i) impedance ii) current iii) power factor iv) voltage across the resistor v) voltage across the capacitor. (5)
- 14 a) Explain the 2 wattmeter method of power measurement using the circuit arrangement. (5)
- b) A 3 phase 4 wire 400V system feeds three loads $10 - j8\Omega$ each connected in star. (5)

- Calculate the line currents in each phase.
- 15 With the help of a neat diagram, explain the working of a nuclear power plant. (10)
- 16 a) Explain the need for high voltage transmission. (5)
b) Explain the principle and operation of circuit breaker used in substation. (5)

MODULE 5

Answer any one full question

- 17 a) Explain different types of dc generators with suitable circuit diagrams and obtain voltage and current expressions of each. (7)
b) The maximum value of flux density in the core of a 250/3000V, 50Hz single phase transformer is 1.5Wb/m². If the emf /turn is 8V, determine i) primary and secondary number of turns ii) area of the core. (3)

OR

- 18 a) Draw and explain the constructional details of 3 phase transformers. (5)
b) A 220V DC shunt motor takes 30A at full load. Find the back emf developed if the armature and shunt field resistances are 0.5Ω and 110Ω respectively. (5)

MODULE 6

Answer any one full question

- 19 a) Draw and explain the constructional details of a 3 phase squirrel cage induction motor. (5)
b) A 6 pole 3phase induction motor operates from a supply whose frequency is 50Hz. Calculate (5)
i) The speed at which the magnetic field of the stator is rotating.
ii) The speed of the rotor when the slip is 0.03

OR

- 20 a) Explain why single phase induction motors are not self-starting. (5)
b) Draw and explain the constructional features of a three phase induction motor. (5)
