

Reg. No. _____

Name: _____

APJ ABDUL KALAM TECHNOLOGICAL UNIVERSITY
SECOND SEMESTER B.TECH DEGREE EXAMINATION, MAY 2017

Course Code: **BE110**Course Name: **ENGINEERING GRAPHICS**Max.Marks:50Duration:3Hours**PART A***Answer ANY Two questions. 10 marks each.*

1. A line AB 100 mm long and end A 30 mm from HP, 50mm from VP, 30 degree inclined to HP and 45 degree inclined to VP. Draw the projections of line and locate its traces. Assume the line in first quadrant.
2. A square pyramid has base 30 mm and side axis 50 mm long. It is freely suspended from one of the corners of its base. The axis is parallel to the VP. Draw the projections of the pyramid.
3. A cube resting one of its base corner in such a way that one of its solid diagonal perpendicular to VP. The length of solid diagonal of cube is 80 mm. Draw the projections of the cube.

PART B*Answer ANY Three Questions. 10 marks each.*

4. Draw the isometric view of a sphere of size 40 mm diameter placed centrally over another sphere of size 60 mm diameter.
5. Draw the orthographic views from T and F directions for the following figure.

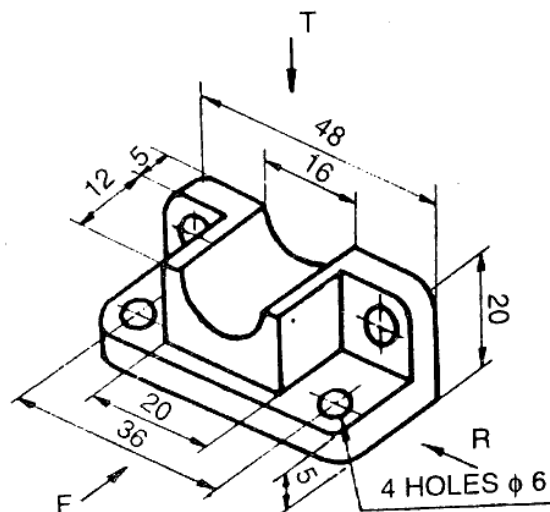

6. A cube of 65 mm long edges has its vertical faces equally inclined to the VP. It is cut by a section plane perpendicular to the VP so that the true shape of the section is a regular hexagon. Determine the inclination of the cutting plane with HP and draw the sectional top view and true shape.
7. A pentagonal prism, having a base with a 30 mm side and a 70 mm long axis, is resting on its base on H.P. such that one of the rectangular faces is parallel to the V.P. It is cut by an auxiliary inclined plane making an angle 45° with the H.P. and passes through the midpoint of the axis. Draw the sectional top view, and the development of the lateral surface of the truncated prism.
8. A square pyramid 40mm base edge and height 80 mm is resting on its base on the ground plane with one edge 45° inclined to PP which is 30 mm in front of the object. The station point is 50 mm. in front of the PP, 100 mm above the ground plane and lies in a vertical plane which is 40mm towards right of center of the pyramid. Draw the perspective view of the block.
