

Reg No.: _____

Name: _____

APJ ABDUL KALAM TECHNOLOGICAL UNIVERSITY
FIRST/SECOND SEMESTER B.TECH DEGREE EXAMINATION, MAY 2019

Course Code: BE 100
Course Name: ENGINEERING MECHANICS

Max. Marks: 100

Duration: 3 Hours

PART A (ANSWER ALL QUESTIONS: 8 X 5 = 40 MARKS)

- 1 State and prove Varignon's theorem of moments. (5)
- 2 Calculate the amount of work done when the point of application is shifted from the point P, $2i - 6j - 3k$ to the point Q, $4i + 3j - k$ by the application of a force $F = 5i + 2j + 7k$. (5)
- 3 With the help of sketches, explain how forces involved in the lifting of a load by a wedge are analysed. (5)
- 4 a) State PappusGuldinus theorem. (2)
 b) Determine the volume of a body generated by rotation of a semi-circular area about a non- intersecting axis using this theorem. (3)
- 5 Define simple harmonic motion? Derive an expression for the acceleration of particle executing simple harmonic motion. (5)
- 6 State and explain D'Álembert's principle. (5)
- 7 Define stiffness and equivalent stiffness of spring.Give the expression for equivalent stiffness of twosprings in series and parallel. (5)
- 8 A lift has an upward acceleration of 1.2 m/s^2 . What force will a man weighing 750 N exert on the floor of the lift? What force would he exert if the lift had an acceleration of 1.2 m/s^2 downwards? (5)

PART B

SET I

(ANSWER ANY 2 QUESTIONS : 2 X 10 = 20 MARKS)

- 9 a) A solid cylinder 30mm diameter and weighing 30N is placed in a triangular channel, as shown in fig. Neglecting friction between the contact surfaces, calculate the normal reactions on the sides of the channel (3)

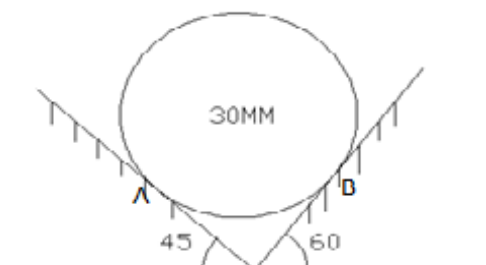

- b) For the system of forces, determine the magnitude,direction and position of the resultant force about A. (7)

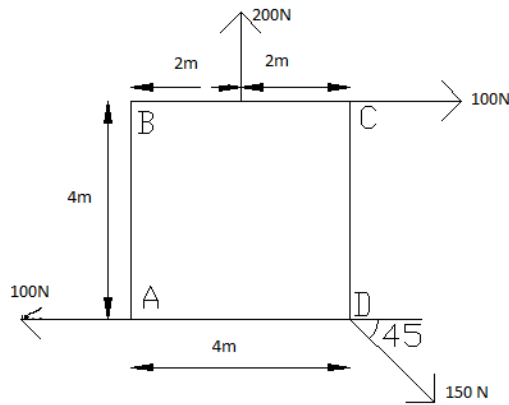

- 10 Members OA,OB and OC form a three member space truss. A weight of 10 kN is suspended at the joint O. Determine the magnitude of forces induced in each of the three member of the truss. (10)

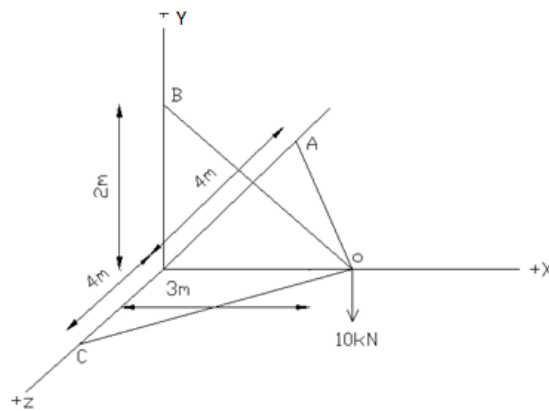

- 11 a) Find the reactions at the supports A(hinged) and B (roller). (4)

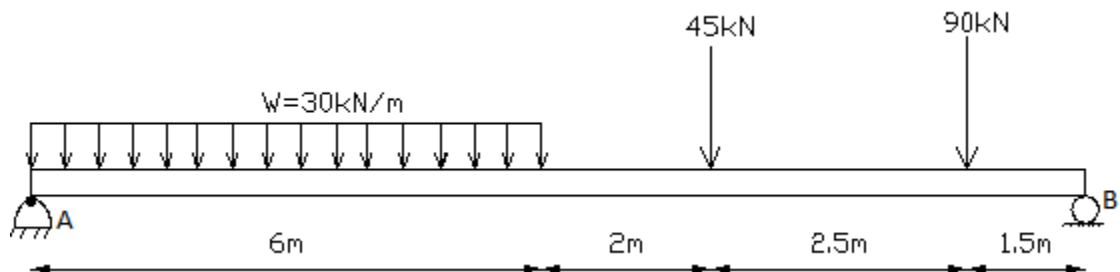

- b) Define couple and explain its characteristics. With the help of a sketch, explain how a force can be resolved into a force and a couple. (6)

SET II

(ANSWER ANY 2 QUESTIONS: 2 X 10 = 20 MARKS)

- 12 A ladder AB 3m in length and weighing 180N, is placed against a wall with A at the floor level and B on the wall. The ladder is inclined at an angle of 60° with the floor. The coefficient of friction between the wall and the ladder is 0.25 and that between floor and the ladder is 0.35. In addition to the self weight of the ladder, it has to support a man weighing 900N, at the top B. To prevent slipping a force is applied horizontally (10)

at the level of floor. Find the minimum horizontal force in this condition.

- 13 a) Define principal axes and principal moment of inertia. (4)
 b) Determine the centroid of the shaded area. Also find moment of inertia of the shaded area about an horizontal axis passing through the centroid. (6)

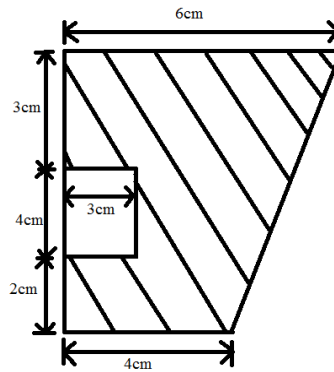

- 14 a) Determine the product of inertia about OX and OY of the trapezium. (5)

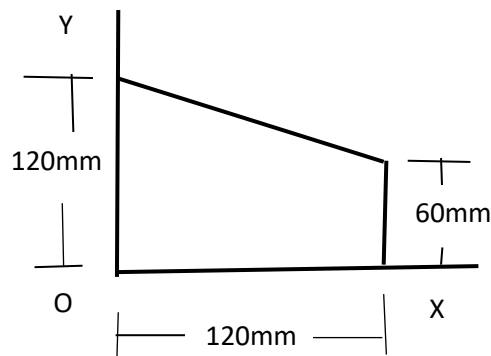

- b) A simply supported beam of span 6 m is loaded with a concentrated load of 5 kN at a distance of 1 m from left end. The beam is also loaded with a uniformly distributed load of 2 kN/m length over a distance of 4 m from the right end of the beam. Find the reactions at the supports of the beam using principle of virtual work. (5)

SET III

(ANSWER ANY 2 QUESTIONS: 2 X 10 = 20 MARKS)

- 15 a) With neat sketches differentiate between motion of translation and motion of rotation. (4)
 b) A bar PQ of length 1 m has its end Q constrained to move horizontally and the other end P constrained to move vertically as shown in the figure given below. The end P moves horizontally with a constant velocity of 5 m/s. The bar makes an angle of 30° with the horizontal. Find the angular velocity of the bar and the velocity of end Q and M. (6)

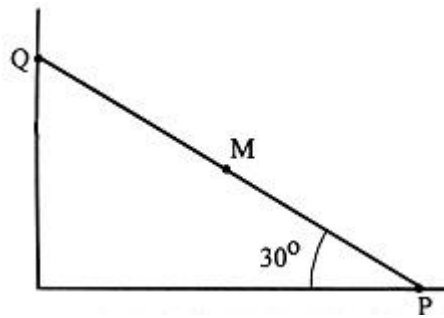

- 16 A clock provided with a seconds pendulum is gaining 160 seconds a day. Find by how much the length of the pendulum should be increased so as to correct the clock. If it is running at correct time at a place where acceleration due to gravity is 9.81 m/s^2 , find by how much the clock will lose or gain if it is taken to a place where the acceleration due to gravity is 9.79 m/s^2 . (10)
- 17 A helical spring under a weight of 20 N extends by 0.3 mm. A weight of 700 N is supported on the same spring. Determine the period and frequency of vibration of the spring when they are displaced vertically by a distance of 0.9 cm and released. Find the velocity of the weight when the weight is 4 mm below its equilibrium position. Take the weight of spring as negligible. (10)
