

Reg. No. \_\_\_\_\_

Name: \_\_\_\_\_

**APJ ABDUL KALAM TECHNOLOGICAL UNIVERSITY**  
**FIRST SEMESTER B.TECH DEGREE EXAMINATION, JULY 2017**  
**BE101-03: INTRODUCTION TO ELECTRICAL ENGINEERING**

Max. Marks: 100

Duration: 3 hrs

**Instructions:**

*Make suitable assumptions and approximations if any data is missing.*  
*Numerical accuracy may be rounded to two decimal places in the final values.*  
*Write units in all numerical answers.*

**PART A**

*Answer ALL questions. Each question carries 4 marks.*

- The terminal i-v characteristics of a practical current source is given in Figure 1. Evaluate the internal resistance parallel to the source. What is the value of resistance to be connected at the output terminals if the output voltage is 4V?

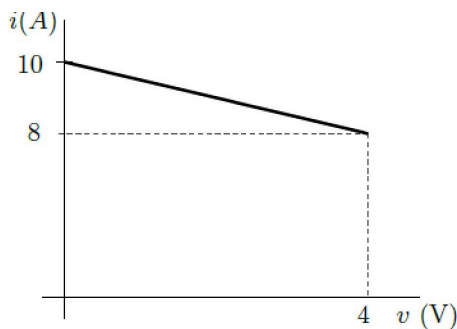

Figure 1: i-v characteristics of a current source

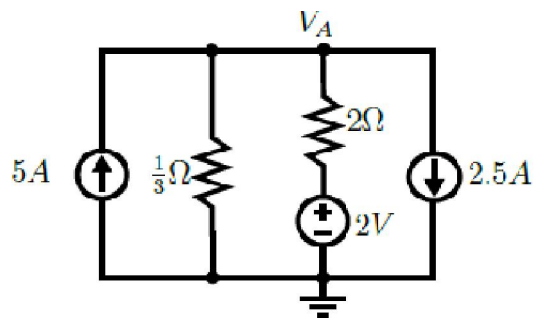

Figure 2: A dc network

- In Figure 2, use node voltage analysis to find the node voltage  $V_A$ .
- Write four differences between electric and magnetic circuits.
- RMS value is "Root of the Mean of the Squares." Find the rms value of the stepped waveform shown in Figure 3. (To save time, it is suggested to avoid integration).

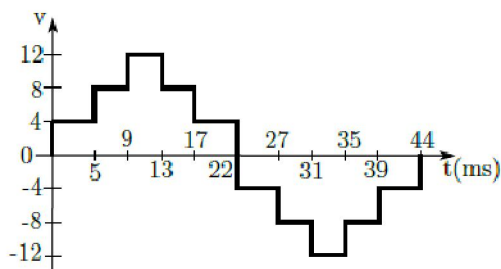

Figure 3: A stepped waveform

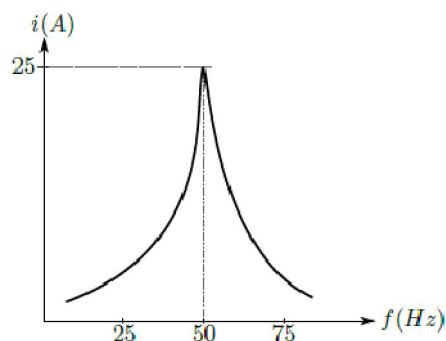

Figure 4: Resonance in a series RLC circuit

5. An R-L series circuit is supplied from an ac voltage source  $v(t) = 12 \cos 4t$  V. The complex power delivered by the source is  $S = 3.6 + j7.2$  VA. Calculate the values of the resistance, R, and the inductance, L. Evaluate the power factor.
6. The variation of current against frequency in a series R-L-C circuit is shown in Figure 4. From the figure, obtain the resonant frequency of the circuit. If at resonance, the total voltage across the RLC series circuit is 100V, evaluate the resistance in the circuit. What is the power factor at resonance? Calculate the power dissipated in the RLC circuit at resonance. The voltage, current etc are expressed in rms values.
7. Define 'power factor' in ac circuits. What is its value for (a) pure resistive circuit, (b) pure inductive and (c) pure capacitive circuits?
8. A three-phase four-wire system has a balanced load in Y-connection. The phase impedance of the load is  $Z_{ph} = 10 \angle 30^\circ \Omega$ . If the line-to-line voltage is  $V_{ll} = 400$  V rms, evaluate the phase currents in polar form. Evaluate the total active power.
9. Draw the circuit diagram for measuring power in a three-phase three-wire system using two wattmeter method, showing clearly the three-phase sources, the two wattmeters and the three-phase loads connected in star connection. Can this method of power measurement be used for measuring power with unbalanced three-phase loads?
10. A three-phase (ABC system assumed) delta connected balanced load is drawing a current of  $10 \angle -30^\circ$  in the AB arm of the delta. If the A- phase voltage is  $230 \angle 0^\circ$ , draw the phasor diagram showing all the three phase-currents, three line-currents and three phase- voltages. Lengths of voltages/currents may be shown at convenient scales. All angles have to be indicated.

### PART B

*Answer ANY FOUR full questions. Each full question carries 10 marks.*

11. (a) State Faraday's laws of electromagnetic induction. Express its mathematical form.

(4)

- (b) Write the terminal v-i relationship for an inductor, L. The current through an inductance 100 mH is shown in Figure 5. Draw the waveform of voltage across the inductor for the given time duration. Calculate the peak energy stored in the inductor.

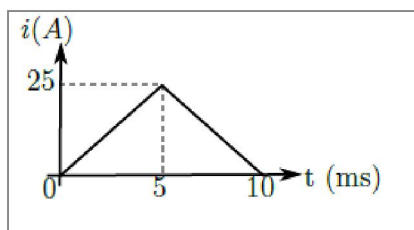

Figure 5: Current in an inductor

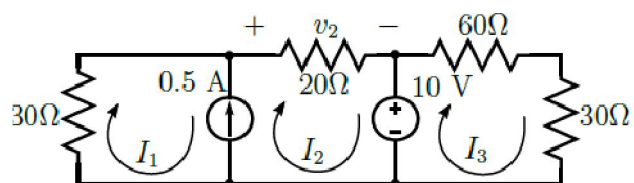

Figure 6: Mesh analysis with current source

12. (a) In Figure 6, find  $v_2$ ,  $I_1$ ,  $I_2$ , and  $I_3$  using mesh analysis. Also evaluate the power delivered by the current source.
- (b) Derive the expression for delta equivalent resistors from a star network. (4)
13. (a) A magnetic circuit consists of a cast steel yoke which has a cross-sectional area of  $200 \text{ mm}^2$  and a mean length of 120 mm. There are two air gaps, each 0.2 mm long. Calculate: (i)

the m.m.f. required to produce a flux of 0.05 mWb in the airgaps; (ii) the value of the relative permeability of cast steel at this flux density. The magnetization curve for cast steel is given by the following (values not present in the table may be approximated as average of the adjacent values):

B(T)	0.1	0.2	0.3	0.4
H (A/m)	170	300	380	460

(b) State whether the following statements are TRUE or FALSE:

- i) In magnetic circuits, flux “flows” like electric current in electric circuits.
- ii) For a steady flux in a magnetic core, there will not be any magnetic loss.
- iii) In reality, the flux density in an air-gap is not the same as that in the magnetic core.
- iv) The slope of B-H curve of a ferromagnetic material such as iron is a constant.

14. (a) Two impedances,  $10\angle -30^\circ$  and  $20\angle 60^\circ$  are connected in parallel. Evaluate the equivalent impedance. What is the nature (capacitive or inductive) of the equivalent impedance? If a current of  $10\angle 45^\circ$  is passing through the parallel combination, calculate the voltage across the combination and express it in rectangular form. Evaluate the currents in each of the impedances. Draw the phasor diagram showing this voltage and all the three currents.

(b) Define peak factor and form-factor. Consider  $v(t) = 500 \cos(100t)$ , a sinusoidal voltage. Evaluate the rms value and peak factor of the voltage waveform.

15. Figure 7 shows a torroid with a mean diameter 95 mm. The cross-section is circular and its diameter is 10 mm. One side of the ring carries 400 turns. The torroid has an air-gap of 0.5 mm on its right half as shown in the figure. It is required to have a flux of 0.44 mWb in the air-gap. The magnetic material of the torroid has a flux density of 1.4T at  $H=1200$  AT/m. Neglect fringing of flux lines.

- (a) Draw an equivalent circuit for the magnetic circuit. (2)
- (b) Evaluate the reluctances of the magnetic circuit (ABCD) and that of the air-gap. Evaluate the total reluctance seen by the mmf source.
- (c) Calculate the current required by the winding for establishing the flux. (2)

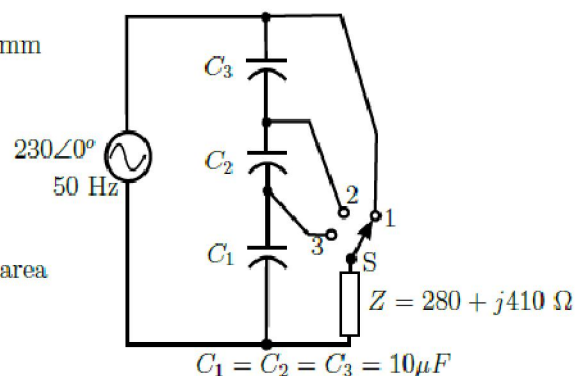
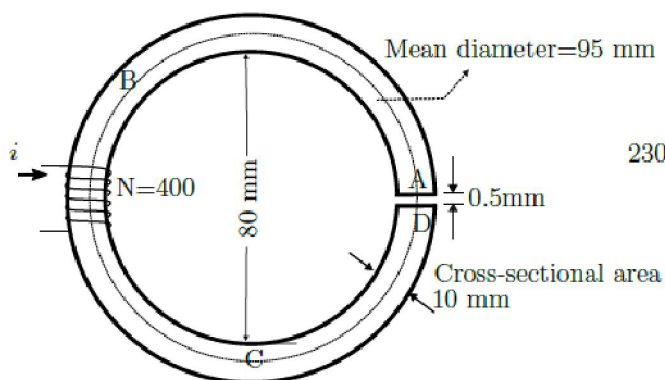

Figure 7: A series-parallel magnetic circuit

Figure 8: An ac loss-less regulator

16. Figure 8 is a loss-less voltage regulating circuit with three capacitors  $C_1, C_2$  and  $C_3$ , all equal to  $10\mu F$ . The ac load  $Z = 280 + j410$  represents a fan motor. The switch S connects the fan impedance to one of the four points 1, 2, and 3. The power supply is  $230\angle 0^\circ$ , at 50 Hz.

- (a) Evaluate the capacitive reactance  $X_C$  and express it in polar form. (1)
- (b) Evaluate the total impedance across the source when the switch  $S$  is in position 1, 2 and 3 ( $Z_1$ ,  $Z_2$  and  $Z_3$ ) respectively.
- (c) For each of the position of  $S$ , calculate the currents taken from the source. Express them in polar form.

## PART C

*Answer TWO full questions. Each full question carries 10 marks.*

17. (a) Define complex power. How is it related to 'Apparent Power'? (4)
- (b) A resistance of  $400\ \Omega$ , an inductance of  $318\ \text{mH}$  are connected in parallel. Find the capacitance of a capacitor which, when connected in parallel with the combination, will produce resonance with a supply frequency of  $1\ \text{MHz}$ . If a second capacitor of capacitance  $23.5\ \text{pF}$  is connected in parallel with the first capacitor, find the frequency at which resonance will occur. What is the Q-factor in each case?

OR

18. (a) Define quality factor. Give the expression for Q-factor in a series R-L-C circuit. (2)
- (b) See Figure 9. The resistance is  $20\ \Omega$  and the capacitive and inductive reactances are  $-j20\ \Omega$  and  $j20\ \Omega$  respectively. If an average power of  $500\ \text{W}$  is dissipated in the  $20\ \Omega$  resistor, find (a)  $|V_{\text{rms}}|$  of the voltage across the resistor, (b)  $|I_L|_{\text{rms}}$ , (c)  $|I_{\text{s}}|_{\text{rms}}$ , (d) the power factor seen by the source, and (e)  $|V_{\text{s}}|_{\text{rms}}$ .

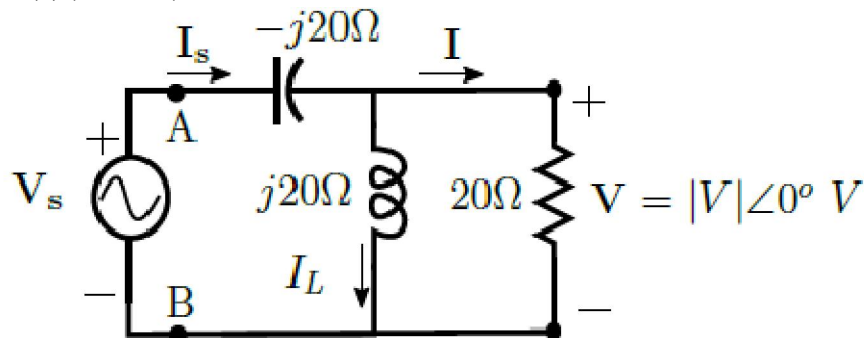

Figure 9: A series-parallel ac circuit

19. (a) A  $600\ \text{V rms}$  three-phase Y-connected source has two balanced  $\Delta$  loads connected to the lines. The load impedances are  $40\ \angle 30^\circ$  and  $50\ \angle -60^\circ$  respectively. Determine the rms line current and the total average power.
- (b) For power measurement in three-phase circuits, under which circumstances will you use (i) Three wattmeter method, (ii) Single wattmeter method and (iii) Two wattmeter method? Write answers in not more than two sentences for each case.

OR

20. The two-wattmeter method is used to determine the power drawn by a three-phase  $440\ \text{V rms}$  motor that is a Y-connected balanced load. The motor draws a power of  $20\ \text{kW}$ . The magnitude of the line current is  $52.5\ \text{A rms}$ . The wattmeters are connected in the A and C lines. Find the reading of each wattmeter. The motor has a lagging power factor. Draw the phasor diagram showing the voltages and currents measured by the two wattmeters.