

10123

Reg. No.: \_\_\_\_\_

Name: \_\_\_\_\_

**APJ ABDUL KALAM TECHNOLOGICAL UNIVERSITY**  
**FIRST SEMESTER B.TECH DEGREE EXAMINATION, JUNE 2016**

**Course Code: BE101-04**

**Course Name: INTRODUCTION TO ELECTRONICS ENGINEERING**

Max. Marks: 100

Duration: 3 Hours

**PART A**

*Answer ALL questions. Each question carries 2 marks*

1. Find out the max current rating for a 10k ohm, 0.5 W resistor.
2. In a particular circuit, a resistor was used with colour band Gray, Red, Black, Gold in respective order and a ceramic capacitor with marking 224. Identify the value of resistance and capacitance.
3. What is the main difference between trimmer and Gang capacitor?
4. Why do LEDs emit light while ordinary diodes do not?
5. Assume that the diode is initially at room temperature ( $27^{\circ}\text{C}$ ). Show the effect of temperature on the V-I characteristics, if the same diode is placed at a temperature of ( $75^{\circ}\text{C}$ )
6. Analyze the importance of forbidden gap in determining the nature of conduction of a material.
7. In BC 107 transistor, B and C stands for what?
8. What is thermal runaway and how does this affect a transistor?
9. CC configuration is used mainly for impedance matching. Give reason.
10. Define the three FET parameters  $g_m$ ,  $r_d$  and  $\mu$ . Prove that  $\mu = g_m \times r_d$
11. Why is JFET called as a Voltage Variable Resistor and which region of V-I curve is used for this purpose?
12. When does a UJT behaves as a diode?
13. Sketch the load line for the diode network shown in the figure. Also find the voltage across the resistor
14. An input of  $10 \sin(100\pi t)$  volt is applied to a diode circuit. The output obtained from the circuit is  $10 + 10 \sin(100\pi t)$  volt. Assume the diode is ideal. Draw the appropriate circuit.
15. Capacitor filter is not suitable for heavy loads. Give reason.

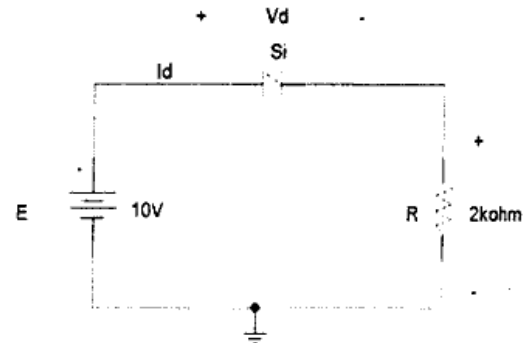

16. Design a circuit to obtain the following transfer characteristics.

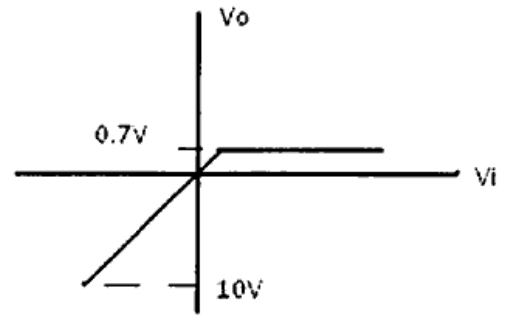

17. What are the advantages of a SMPS over a linear voltage regulator?

18. What is the need for electron gun in CRO?

19. Draw the block diagram of digital Multimeter.

20. A sinusoidal waveform is displayed on CRO screen with one full cycle in two divisions. If the time-base knob is 0.5 ms position, find the frequency of the waveform.

### PART B

*Answer any 4 complete questions each having 10 marks*

21. a) Discuss the working and various parameters of relays with relevant sketches. (5)

b) Explain the constructional features of metal film resistor. (5)

22. a) Describe the construction of a commercial electrolytic capacitor. (5)

b) Which diode is called tuning diode and why? (5)

23. a) Draw the circuit diagram of an RC coupled amplifier. (5)

b) Give reason for the drop in gain in the frequency response of RC coupled amplifier at lower frequencies and higher frequencies. (5)

24. a) Why stabilization of operating point is necessary in a transistor? (3)

b) List the main differences between a FET and a BJT. (3)

c) Determine the dc bias voltage  $V_{CE}$  and the current  $I_C$  for the voltage divider configuration shown in the following figure:

(4)

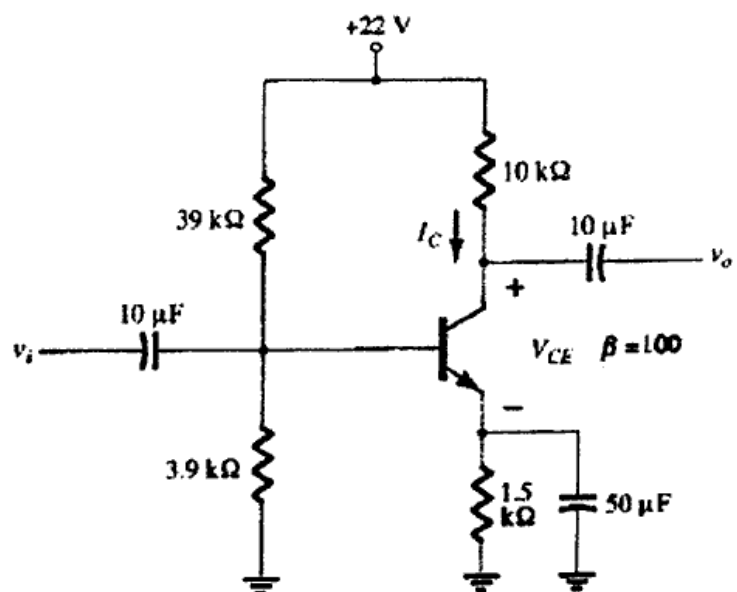

25. Give the construction details of an FET and qualitatively analyse, how the current flow from drain to source is controlled by the voltage applied at the gate terminal. (10)

Answer any 2 complete questions each having 10 marks

26. a) Calculate  $\alpha_{dc}$  and  $\beta_{dc}$  for a transistor if  $I_C$  is measured as 1mA, and  $I_B$  is  $25\mu A$ . Also determine the new base current to give  $I_C = 5mA$ . (4)
- b) Explain the working of the given circuit and Sketch  $V_o$  and transfer characteristics for the input shown. (6)

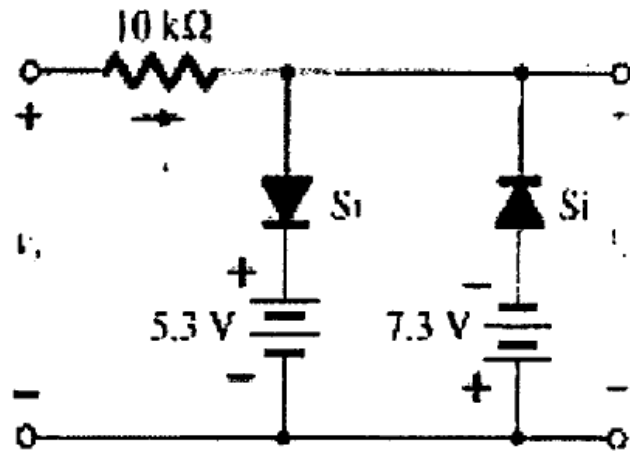
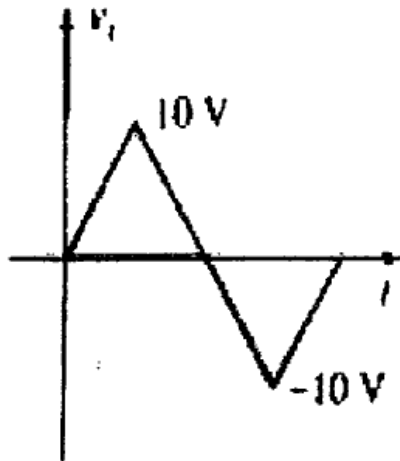

27. a) Draw the block diagram of a function generator. (4)
- b) A  $5 k\Omega$  load is fed from a bridge rectifier connected across a transformer secondary whose primary is connected to 460V, 50 Hz supply. The ratio of number of primary turns to secondary turns is 2:1. Calculate d.c load current, d.c load voltage, ripple voltage and PIV rating of diode. (6)
28. Mention the procedure for checking the following devices:  
a) UJT b) SCR c) JFET d) BJT e) capacitor (10)

http://www.ktuonline.com

Whatsapp @ 9300930012

Your old paper & get 10/-

पुराने पेपर्स भेजे और 10 रुपये पायें,

Paytm or Google Pay से