

10122

Reg. No.: _____

Name: _____

FIRST SEMESTER B.TECH DEGREE EXAMINATION, JANUARY 2018

Course Code: BE101-04

Course Name: INTRODUCTION TO ELECTRONICS ENGINEERING

Max. Marks: 100

Duration: 3 Hours

PART A

Answer ALL questions. Each question carries 2 marks

1. Color band sequence on a resistor is Yellow, Violet, Silver and Red. What is its resistance value?
2. What is the working principle of transformer?
3. A number 104 is written on the body of a ceramic capacitor. What is the value of capacitance?
4. Draw piecewise linear model of diode.
5. Differentiate between Zener and avalanche breakdown.
6. A Silicon diode has reverse saturation current of $2.5\mu\text{A}$ at 300K. Find forward voltage for a forward current of 10Ma.
7. Discuss the role of bypass capacitor in a single stage RC coupled amplifier?
8. The widely used voltage amplifier configuration is CE, mention the reason?
9. Derive the relationship between α and β .
10. Draw the equivalent circuit of a UJT.
11. Write 4 advantages of FET over BJT.
12. How FET functions as voltage variable resistor?
13. Why is the ripple factor of HWR higher than that of FWR?
14. Design a silicon diode clipper for transfer characteristics in figure below?

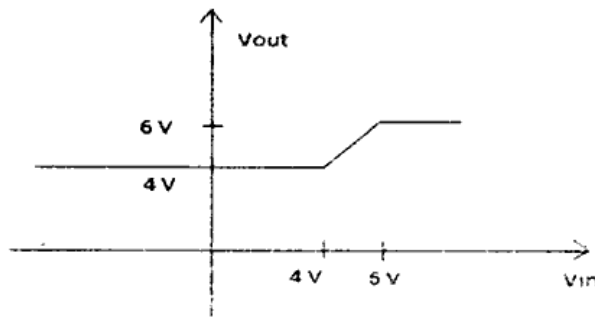

15. Assuming drop across diode is 0.6V, find output voltage V_0 ?

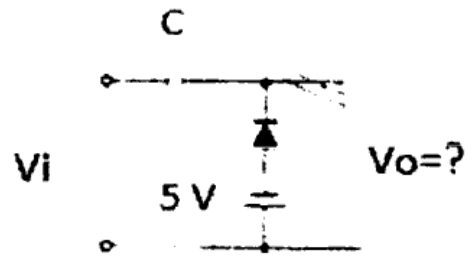
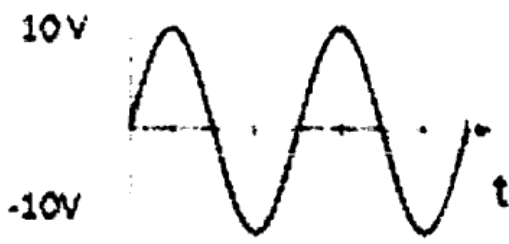

16. Find the maximum and minimum values of Zener diode current.

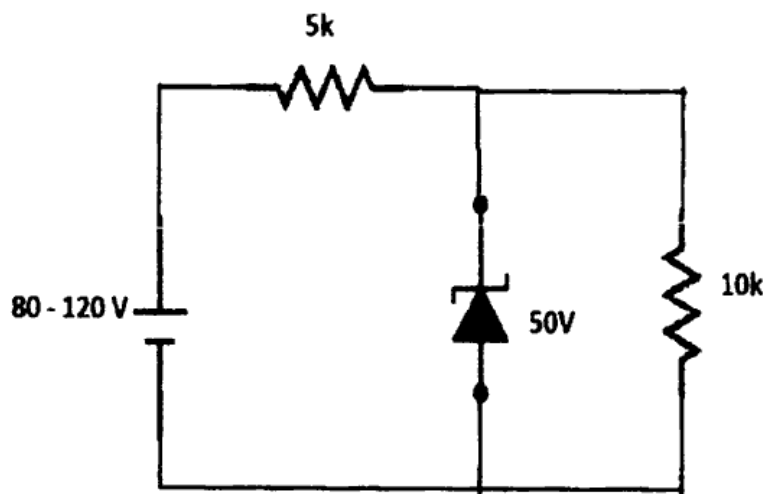

- 17. A CRO is set to a time base of 0.1ms/div with a 2V/div amplitude. Sketch the display of a pulse signal waveform with a frequency 1kHz and amplitude 8V peak.
- 18. What is precision and resolution of measuring instruments?
- 19. Compare an analog multimeter with a digital multimeter.
- 20. How testing of a diode is carried out?

PART B

Answer any 4 complete questions each having 10 marks

- 21. Differentiate the capacitors based on the types of dielectric used and explain their construction. (10)
- 22. A) Explain the constructional details of carbon composition resistors? (5)
B) Explain the formation of a potential barrier in a p-n junction and show the polarity of the Barrier potential. http://www.ktuonline.com (5)
- 23. A) Explain the working of an RC coupled amplifier with a neat circuit diagram. (6)
B) Explain the frequency response curve. (4)

http://www.ktuonline.com

http://www.ktuonline.com

24. A) With reference to the following circuit, draw the load line and mark the Q point of a Silicon transistor operating in CE mode based on the following data ($\beta = 80$, $R_s = 47k\Omega$, $R_L = 1k\Omega$, neglect I_{CBO})

(6)

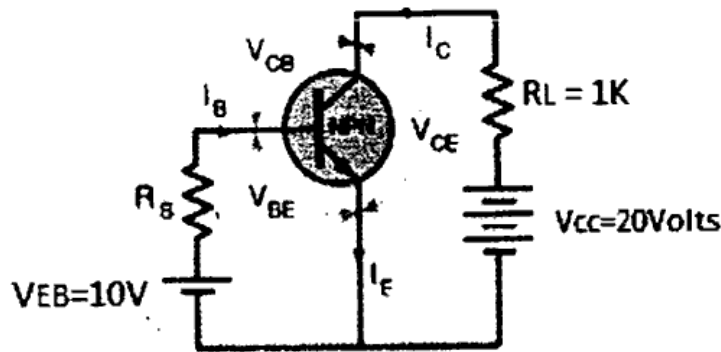

- B) Sketch the forward characteristics of a SCR. Explain the importance of Holding current in a SCR. (4)

25. With a neat diagram draw structure of n channel E-MOSFET and explain different regions of operation. (10)

Answer any 2 complete questions each having 10 marks

26. A) Draw the circuit of a bridge rectifier and explain its working. (5)
B) Derive the expressions for V_{rms} , V_{dc} , Ripple factor, Rectification Efficiency, Peak Inverse Voltage. (5)
27. A) With the help of suitable block diagram, discuss the working principle of the electronic device which is used in laboratories for generating the various standard waveforms. (5)
B) Draw the block diagram of DC power supply and list out the functions of each block. (5)
28. With neat schematic diagram, explain the working of a CRO. List its applications. (10)